

RANCH RIDING - PATTERN 6

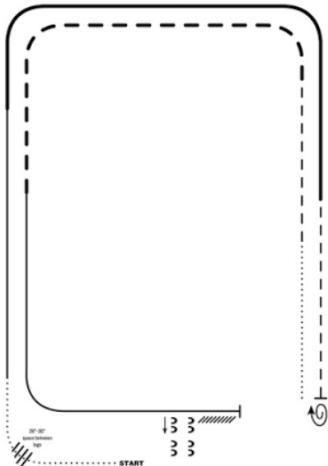

1. Walk
2. Walk over logs
3. Lope right lead
4. Extended lope right lead
5. Trot
6. Stop, 1/2 turn right
7. Walk
8. Trot
9. Extended trot
10. Lope left lead
11. Stop and back
12. Side pass right

Note: The drawn description of this pattern is only intended for the general depiction of the pattern. Exhibitors should utilize the arena space to best exhibit their horses.

LEGEND

- Walk
- Extended Walk
- - - Trot
- - - Extended Trot
- Lope
- Extended Lope
- /// Back
- W Lead Change

PATTERN 2- LOPE TOWARD

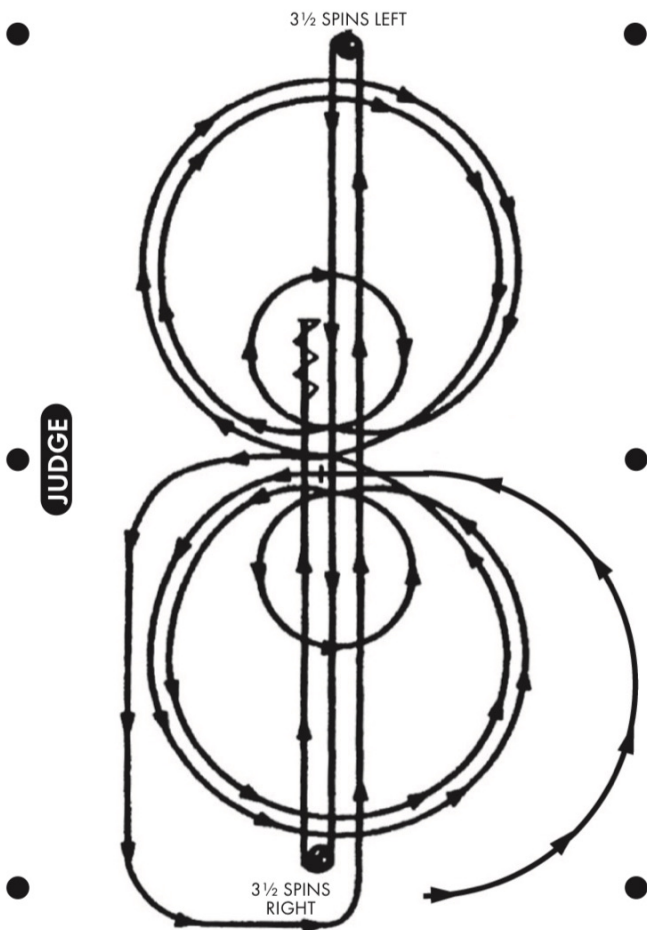

Begin on left lead. At the center, without stopping or breaking gait, begin pattern facing toward the judge. Refer to rule 20.6

1. Beginning on the left lead, complete 3 circles to the left. The first one large and fast, the second small and slow, the third large and fast Change leads at the center of arena
2. Complete 3 circles to the right. The first one large and fast, the second small and slow, and the third large and fast Change leads at the center of arena.
3. Continue loping to run down.
4. Run to far end past the marker to a sliding stop. Hesitate.
5. Complete 3 1/2 spins to the left. Hesitate.
6. Run to far end past marker to a sliding stop. Hesitate.
7. Complete 3 1/2 spins to the right. Hesitate.
8. Run past center marker to a sliding stop. Hesitate.
9. Back at least 10 feet. Hesitate to complete pattern.

PATTERN 10-LOPE TOWARD

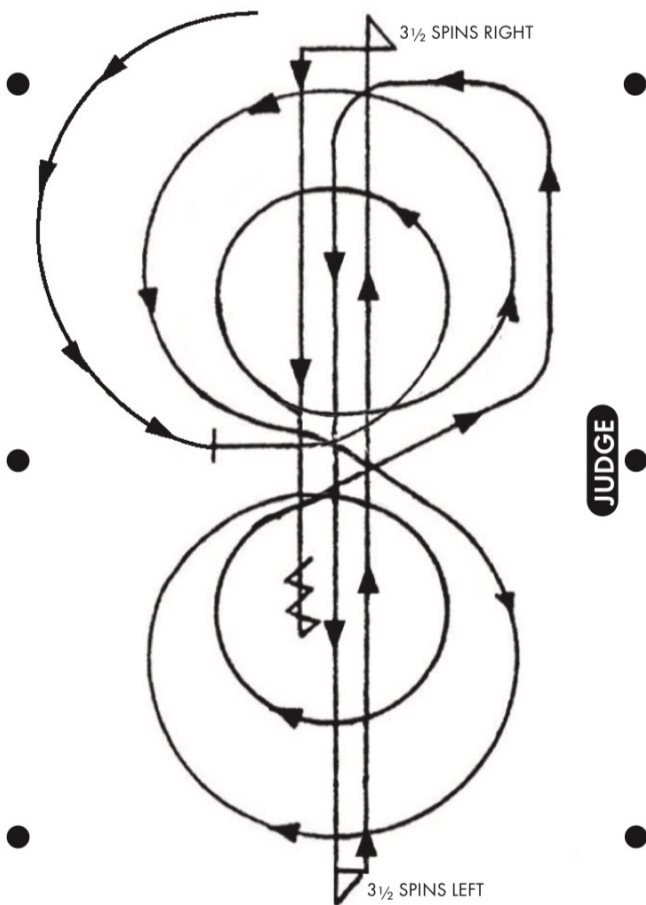

Start on left lead. At the center, without stopping or breaking gait, begin pattern facing toward the judge. Refer to rule 20.6.

1. Beginning on the left lead, complete 2 circles to the left. The first circle small and slow, the second circle large and fast. Change leads at the center of arena.
2. Complete 2 circles to the right. The first circle large and fast, the second circle small and slow. Change leads at the center of arena.
3. Continue around end of arena without breaking gait or changing leads, run down center of arena past end marker, and execute a square sliding stop.
4. Complete 3 1/2 spins to the left.
5. Run down center of arena past end marker, and execute a square sliding stop.
6. Complete 3 1/2 spins to the right.
7. Run down center of arena past center marker, and execute a square sliding stop.
8. Back up at least 10 feet. Hesitate to complete pattern.

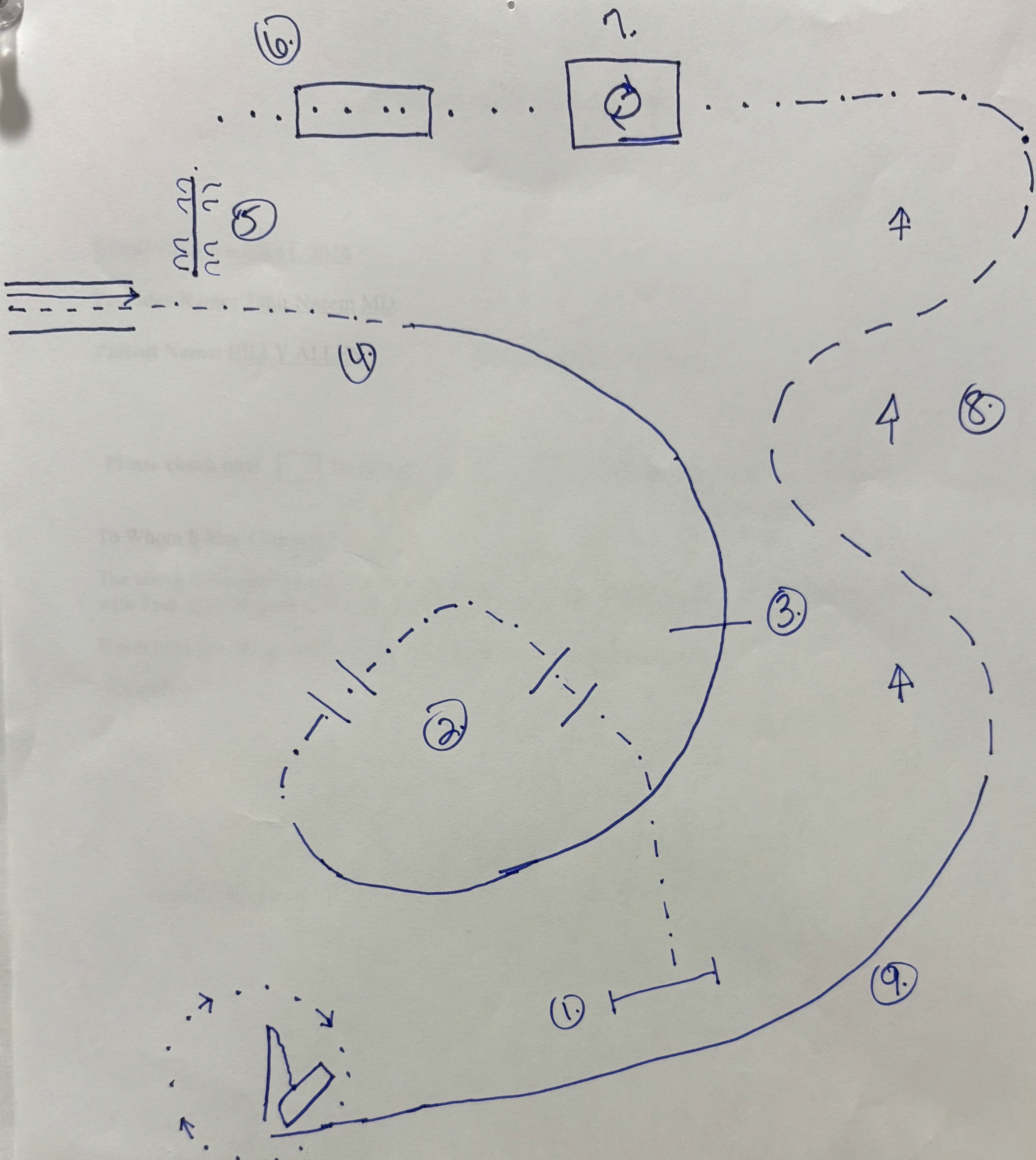

- (1) Right Hand gate
 - (2) Trot logs
 - (3) Lope Left over log
 - (4) Trot into Chute, back out
 - (5) Side PASS Right over log
 - (6) Turn either way to Face Bridge, walk over
 - (7) walk into Box 360° pivot, either way
 - (8) trot, then extended Trot Serpentine
 - (9) Lope Right lead to drag, walk or Trot circle. End
- * youth trot Right circle And Stop.*

VRH AND RHC RANCH REINING PATTERN 2

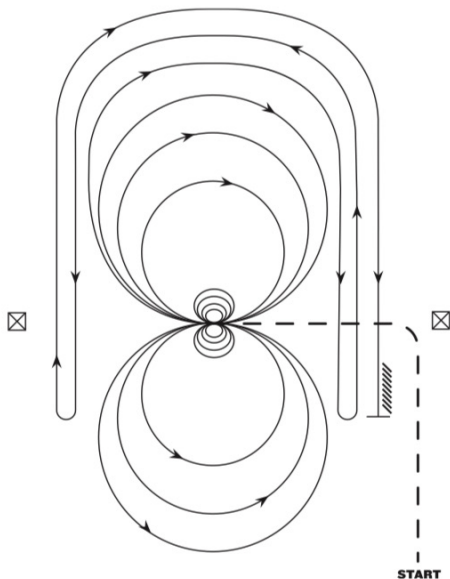

Mandatory Markers along Fence or Wall: The judge shall indicate with markers on arena fence or wall the center of pattern.

Ride pattern as follows: Trot to center of arena and stop or walk before departure.

1. Beginning on right lead, complete two circles to the right - the first one large and fast; the second one small and slow. Stop at center.
2. Complete 4 spins to the right. Hesitate.
3. Beginning on left lead, complete two circles to the left - the first one large and fast; the second one small and slow. Stop at center.
4. Complete 4 spins to the left. Hesitate.
5. Beginning on the right lead, complete a large fast circle to the right and change leads at center of arena. Complete a large fast circle to the left and change leads at center of arena.
6. Begin a large fast circle to the right, but do not close this circle. Run down the right side of the arena, past the center marker, and do a left roll back at least 20 feet from the wall or fence.
7. Continue back around the previous circle, but do not close this circle. Run down the left side of the arena, past the center marker, and do a right roll back at least 20 feet from the wall or fence.
8. Continue back around previous circle, but do not close this circle. Run down right side of the arena, past the center marker, and do a sliding stop at least 20 feet from the wall or fence. Back up at least 10 feet. Hesitate to show completion of pattern.